

ELEVATION

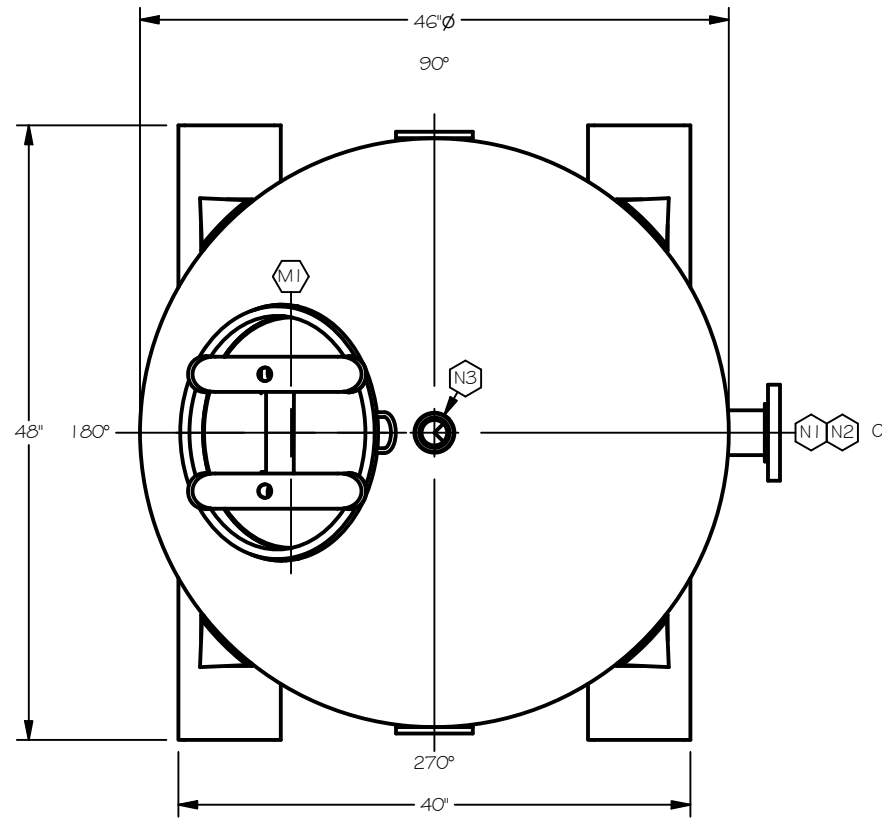

PLAN



MARK	SERVICE	DESCRIPTION	LOCATION
N4	DRAIN	2" 150# FLANGE W/ 1/2" PLUG	BOTTOM HEAD
N3	VENT	2" NPT	TOP HEAD
N2	OUTLET	3" 150# FLANGE	SIDE SHELL
N1	INLET	3" 150# FLANGE	SIDE SHELL
M1	MANWAY	14"x18" ELL.	TOP HEAD

NOZZLE SCHEDULE

REVISION HISTORY

REV	DESCRIPTION	BY	DATE
6	UPDATE VESSEL STANDARDS	JAK	10/24/16

**VESSEL STANDARDS:**

- VESSEL MATERIAL: **SA-516-70**
- HEAD THICKNESS: **3/16"** HEAD TYPE: **CODE F#D**
- SHELL THICKNESS: **1/4"**
- COATINGS:
  - INTERIOR LINING: **EPOXY PHENOLIC**
  - EXTERIOR COAT: **EPOXY BASE W/ URETHANE TOP**
- INTERNALS:
  - PVC**
- VESSEL PROPERTIES:
  - MAWP: **75 PSI** AT **130 f**
  - EMPTY SHIP WEIGHT: **1350 LBS**
  - TOTAL VESSEL VOLUME: **69.5 FT<sup>3</sup>**
  - MAXIMUM MEDIA FILL: **60 FT<sup>3</sup>**

PROJECT	
CP-1000	
PROJ. NO.	SALES
PO. NO.	
THIS DRAWING AND DESIGN ARE THE PROPERTY OF TIGG LLC. AND SHALL NOT BE REPRODUCED IN WHOLE OR IN PART. NOR EMPLOYED FOR ANY PURPOSE OTHER THAN SPECIFICALLY PERMITTED IN WRITING BY TIGG LLC. THIS DRAWING LOANED SUBJECT TO RETURN BY DEMAND.	
DRAWN BY	JB
DESIGN BY	BB
CHECKED BY	BB
DATE	11/19/2005
SCALE	NTS

TIGG LLC.

GENERAL ARRANGEMENT

CP-1000-1001

6