

ELEVATION

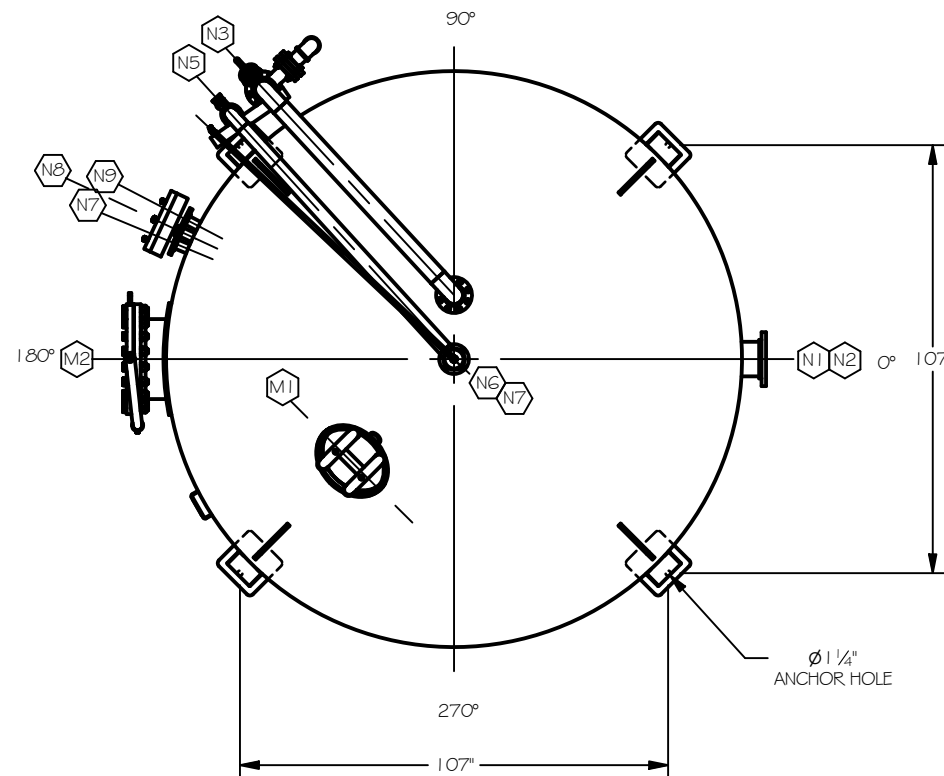

PLAN

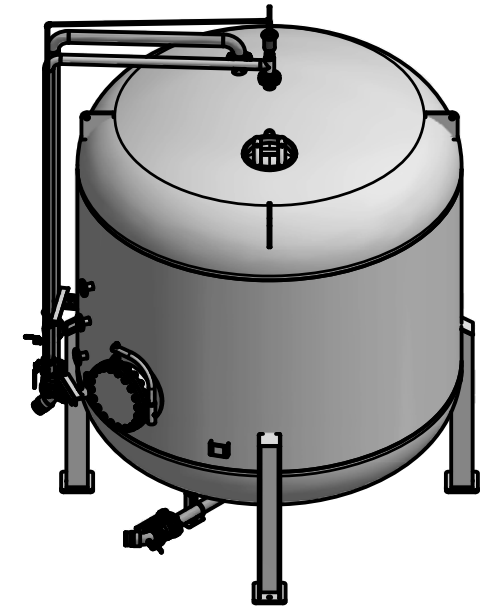

MARK	SERVICE	DESCRIPTION	LOCATION
N9	SAMPLE - 3	2" 150# FLANGE	SIDE SHELL
N8	SAMPLE - 2	2" 150# FLANGE	SIDE SHELL
N7	SAMPLE - 1	2" 150# FLANGE	SIDE SHELL
N6	DRAIN	2" 150# FLANGE	BOTTOM HEAD
N5	VENT	3" 150# FLANGE	TOP HEAD
N4	CARBON OUT	4" 150# FLANGE	BOTTOM HEAD
N3	CARBON IN	4" 150# FLANGE	TOP HEAD
N2	OUTLET	8" 150# FLANGE	SIDE SHELL
N1	INLET	8" 150# FLANGE	SIDE SHELL
M2	MANWAY	20" 150# FLANGE W/ BLIND	SIDE SHELL
M1	MANWAY	14"x18" ELL. MANWAY	TOP HEAD

NOZZLE SCHEDULE

REVISION HISTORY

REV	DESCRIPTION	BY	DATE
0			

VESSEL STANDARDS:

VESSEL MATERIAL: SA-516-70

- HEAD THICKNESS: 5/8" HEAD TYPE: 2:1 ELLIPTICAL
- SHELL THICKNESS: 5/8"

COATINGS:

- INTERIOR LINING: PLASITE 4110 - DFT 35-45(MAX)
- EXTERIOR COAT: EPOXY BASE W/ URETHANE TOP

INTERNALS:

- 304 STAINLESS STEEL

VESSEL PROPERTIES:

- MAWP: 125 PSIG / -15 PSIG AT 150 f
- EMPTY SHIP WEIGHT: 18,500 LBS
- TOTAL VESSEL VOLUME: 1,325 FT³

PROJECT		CK-20K-12	
PROJ. NO.	STANDARD		
PO. NO.			
THIS DRAWING AND DESIGN ARE THE PROPERTY OF TIGG LLC. AND SHALL NOT BE REPRODUCED IN WHOLE OR IN PART. NOR EMPLOYED FOR ANY PURPOSE OTHER THAN SPECIFICALLY PERMITTED IN WRITING BY TIGG LLC. THIS DRAWING LOANED SUBJECT TO RETURN BY DEMAND.			
DRAWN BY	JB		
DESIGN BY	JB		
CHECKED BY	BB		
DATE	2/1/2018		
SCALE	NTS		
TIGG LLC.		GENERAL ARRANGEMENT	
		CP-20K-12-GA-001	0