

ELEVATION

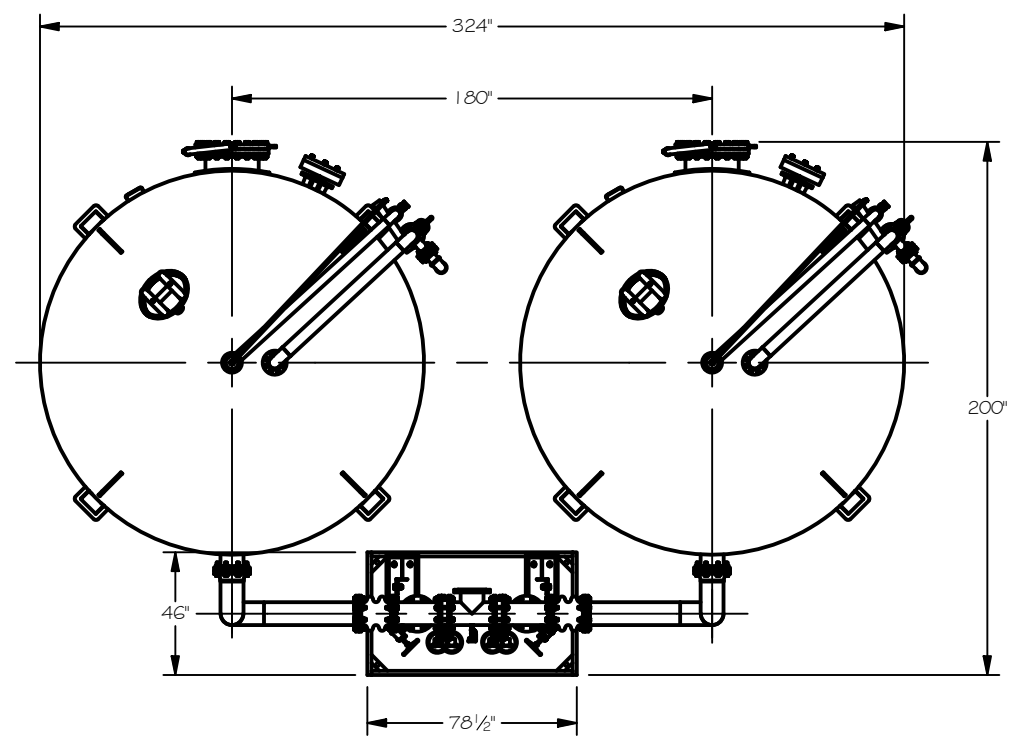

PLAN

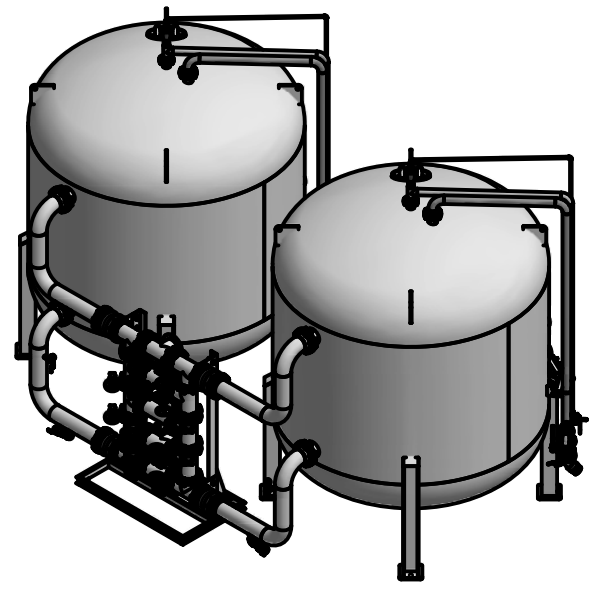

SYSTEM SPECIFICATIONS:

- MAXIMUM SERIES FLOW: **1,000 GPM**
- MAXIMUM PRESSURE: **125 PSIG**
- MAXIMUM TEMPERATURE: **150°F**
- EMPTY VESSEL WEIGHT: **18,500 LBS**
- VESSEL OPERATING WEIGHT: **98,000 LBS**
- PIPE RACK OPERATING WEIGHT: **6,000 LBS**
- SYSTEM OPERATING WEIGHT: **202,000 LBS**

FOR VESSEL INFORMATION SEE DRAWING # CP-20K-12-GA-001
FOR P&ID SEE DRAWING # CP-20K-12-PL-002

REVISION HISTORY			
REV	DESCRIPTION	BY	DATE
0			4/1/2016

PROJECT	
CP-20K-12 (SYSTEM)	
PROJ. NO.	
PO. NO.	
THIS DRAWING AND DESIGN ARE THE PROPERTY OF TIGG LLC. AND SHALL NOT BE REPRODUCED IN WHOLE OR IN PART, NOR EMPLOYED FOR ANY PURPOSE OTHER THAN SPECIFICALLY PERMITTED IN WRITING BY TIGG LLC. THIS DRAWING LOANED SUBJECT TO RETURN BY DEMAND.	
DRAWN BY	JB
DESIGN BY	JB
CHECKED BY	BB
DATE	2/1/2018
SCALE	NTS

TIGG LLC.

SYSTEM GENERAL ARRANGEMENT

CP-20K-12-GA-002

PRELIMINARY