

TOP VIEW

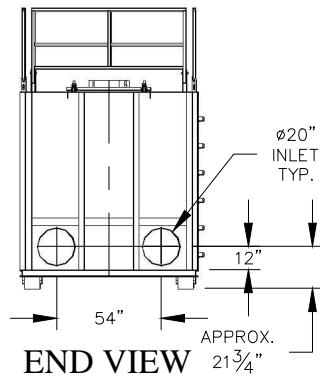

END VIEW

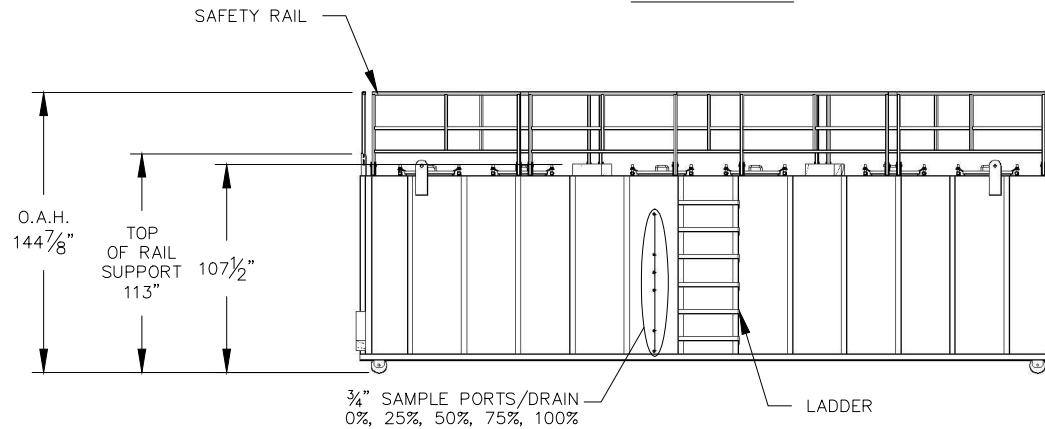

FRONT VIEW

8	ADD SAFETY RAILS	JB	1/21/13
7	REVISE STANDARDS	JB	8/23/07
6	CHANGE PRESSURE RATING TO 1 PSI	JB	3/8/07
NO.	REVISION	BY	DATE

PROJECT	
NB-20	
PROJ. NO.	SALES
P.O. NO.	
THIS DRAWING AND DESIGN ARE THE PROPERTY OF TIGG CORP. AND SHALL NOT BE REPRODUCED IN WHOLE OR IN PART, OR EMPLOYED FOR ANY PURPOSE OTHER THAN SPECIFICALLY PERMITTED IN WRITING BY TIGG CORP. THIS DRAWING LOANED SUBJECT TO RETURN ON DEMAND.	
DRAWN BY	JB
DESIGN BY	JB
CHKD. BY	JJ
DATE	11/28/11
SCALE	NTS



GENERAL ARRANGEMENT

DWG. NO.	NB-20-1001	REV.	8
----------	------------	------	---

VESSEL STANDARDS

VESSEL MATERIALS : SA-36	LIQUID DRAIN ASSEMBLY : 3/4" NPT
LINING : EPOXY	VOLUME OF MEDIA BED : 640 FT ³
EXTERIOR PAINT : EPOXY BASE W/ URETHANE TOP COAT	SHIP WT. EMPTY : 15,000 LBS
INTERNALS : 304 STAINLESS STEEL POR-O-SEPTA	MAX. OPERATING PRESSURE : 1 PSI
VESSEL ACCESS : 42" x 24" ACCESS HATCH (6 PLCS.)	MAX. OPERATING TEMPERATURE : 180°